

INSTRUCTION MANUAL

L SHAPED SECTIONAL

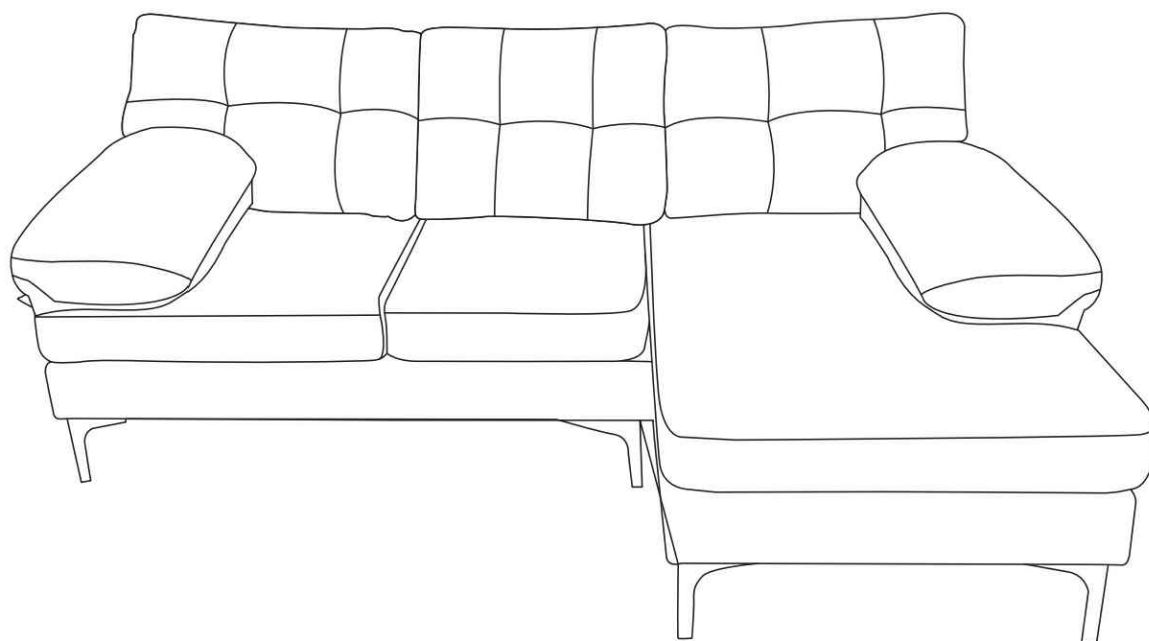

COMPONENTS

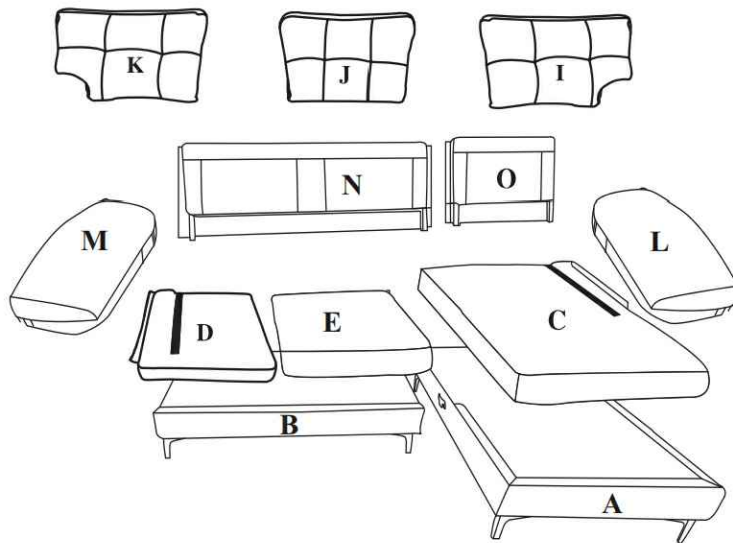

P  8 X Sofa Leg

Q  16 X Bolt $\phi 8*20\text{mm}$

R  8 X Bolt $\phi 8*60\text{mm}$

S  8 X Flat Washer

T  1 X Allen Key

TOOLS REQUIRED:  SCISSORS (NOT INCLUDED)

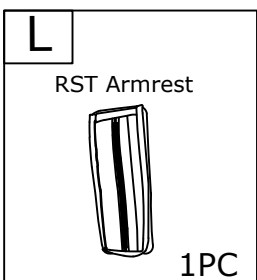
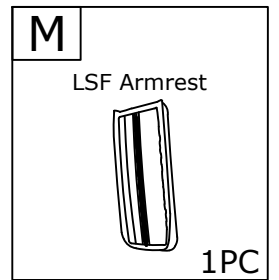
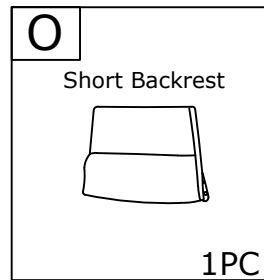
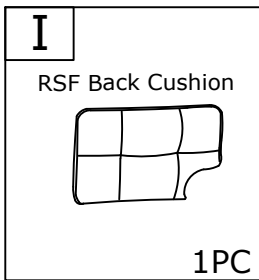
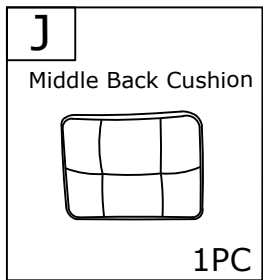
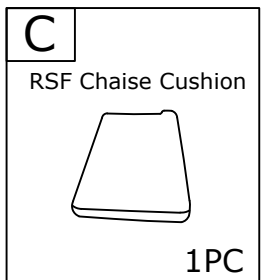
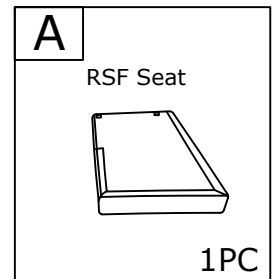
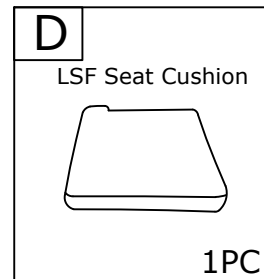
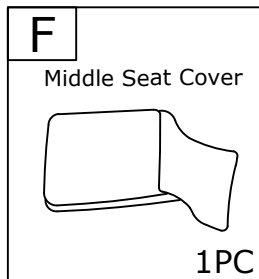
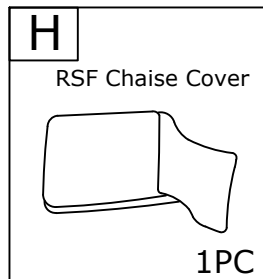
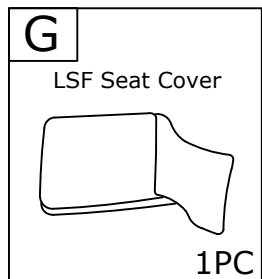
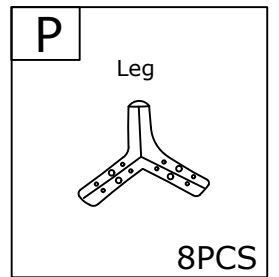
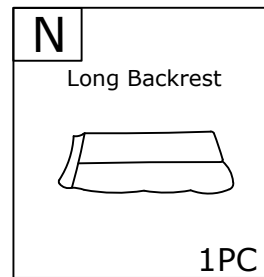
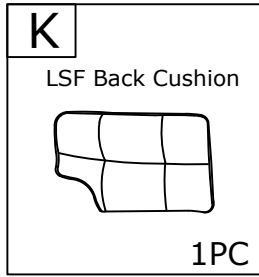
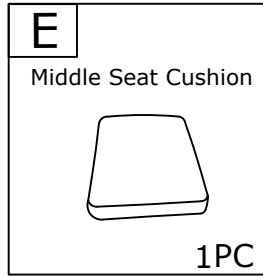
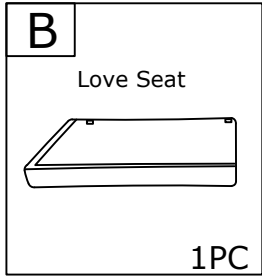

ASSEMBLY STEPS

STEP 1 Attach legs(P)to the love seat(B) and RSF Seat(A) with bolts(Q).

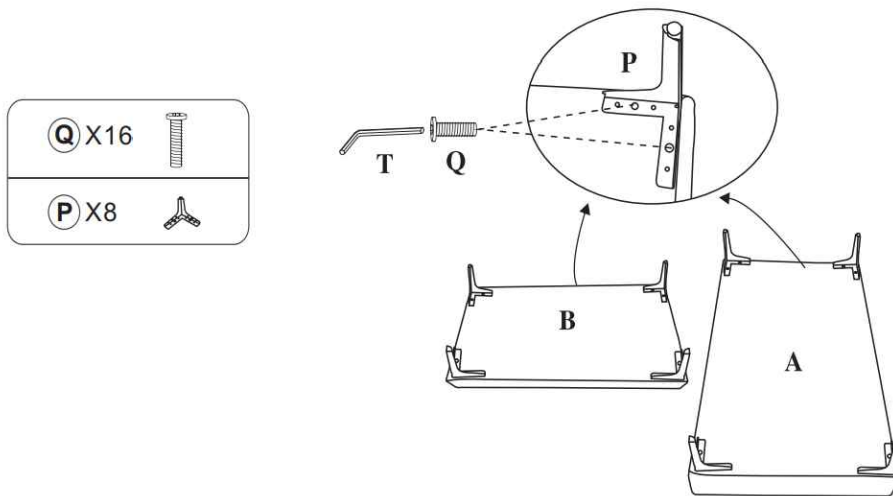

STEP 2 Slide RSF seat into the brackets on the love seat.

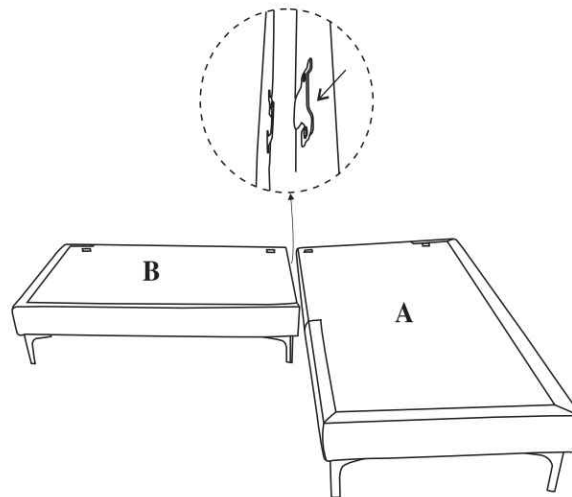

STEP 3 Insert short backrests(O) and long backrest(N) into the designated holes, using bolts (R) and flat washers(S) to secure it.

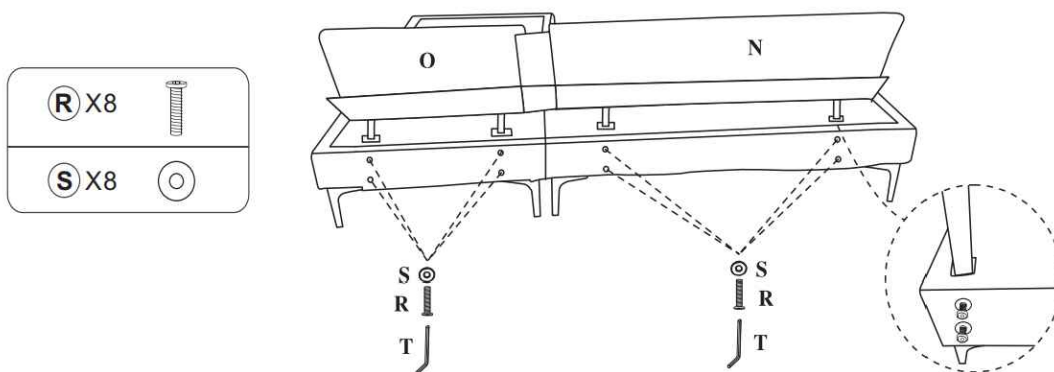

STEP 4

Use scissors to open all the vacuum sealed cushions and armrests. It may take 24-72hrs to fully expand back to its original shape & firmness.

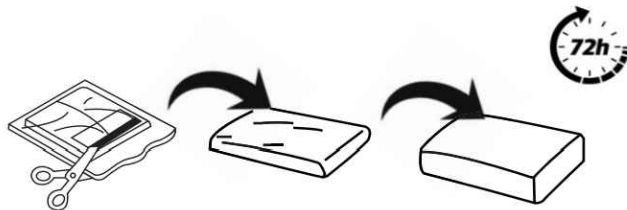

STEP 5

Stuff all the seat cushions into the corresponding seat covers

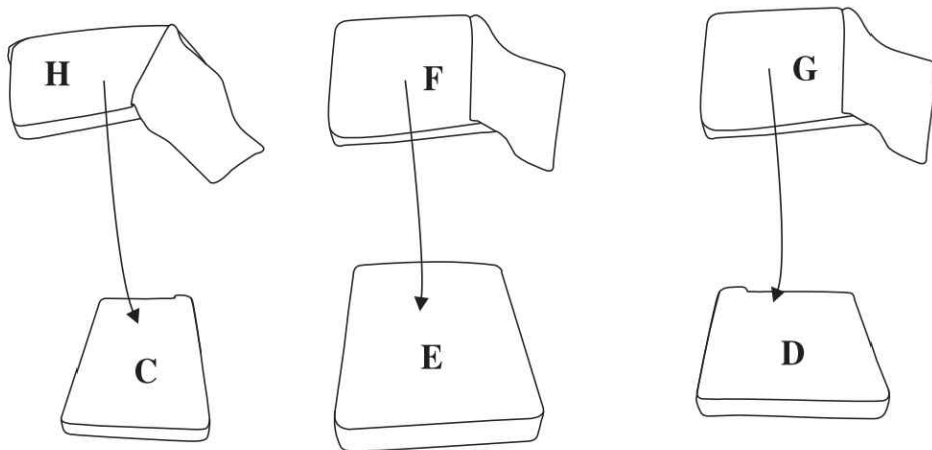

STEP 6

Place three seat cushions on the sofa.

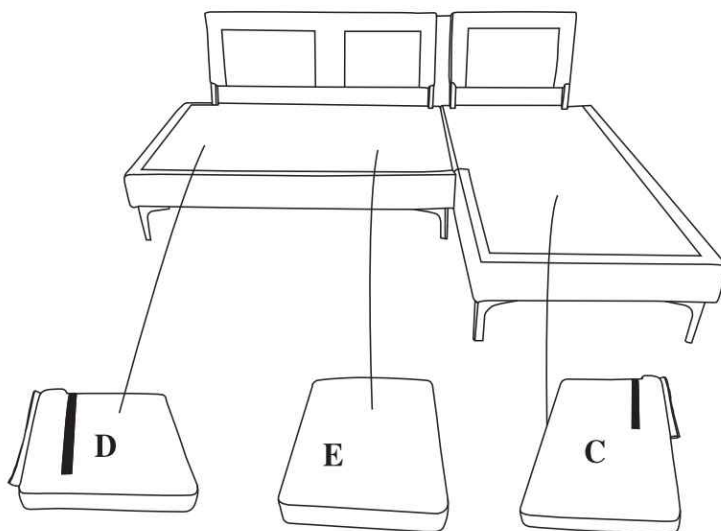

STEP 7 Attach armrests(L&M) into designated position.

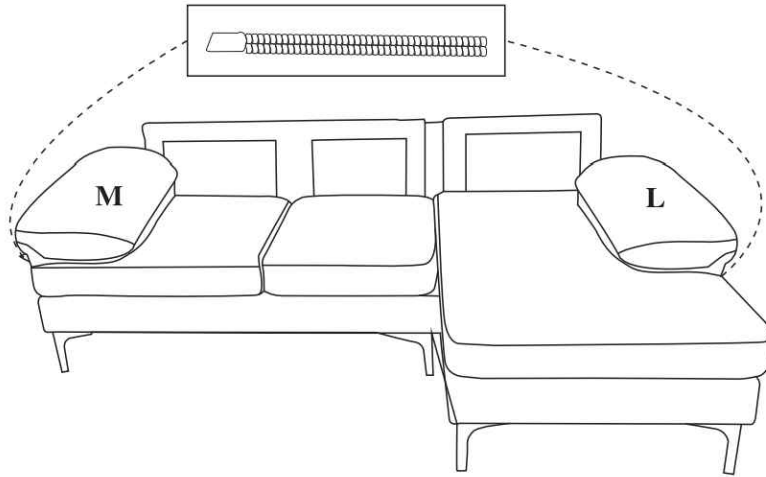

STEP 8 Place three back cushions on the sofa.

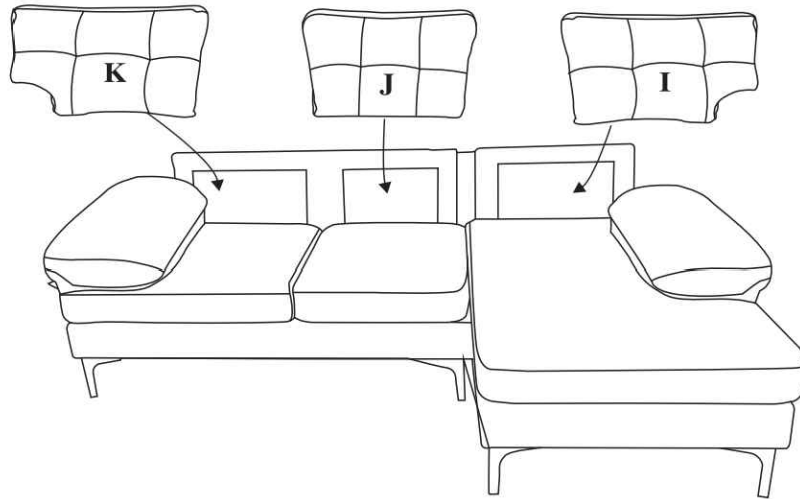

STEP 9

